

3ª EDIZIONE



TR
TUTTORETTIFICHE®

NEWS

KÖRTIG®



LA GRANDE INTESA

Tutto rettifiche ha da sempre l'obiettivo di offrire al rettificatore un servizio completo puntando sulla qualità.

Dopo anni di collaborazione siamo lieti di comunicarvi la nostra nuova partnership con Körting, marchio tedesco che lavora da più di venti anni con le principali aziende costruttrici del comparto guarnizioni per automotive.

Körting è attrezzata con stampi, attrezzature e materie prime necessarie per

la produzione a 360 gradi di guarnizioni.

Tutto rettifiche offre l'esperienza maturata grazie al rapporto di stima e fiducia costruito nel tempo con le officine di rettifica di tutta Italia.

Il continuo scambio di conoscenza (knowledge) e la consapevolezza di essere due marchi storici che operano ognuno nel proprio settore da diversi anni è il motore di questa nuova collaborazione.

"Quando iniziammo a lavorare con Körting per la creazione delle prime guarnizioni unificate sapevamo che da lì a poco sarebbe nata una stretta collaborazione e che avrebbe portato ad una svolta non solo alle officine di rettifiche, ma anche al mercato automotive stesso!" **dice Antonio Viola CEO di Tutto rettifiche.**

Negli ultimi anni, considerati i continui cambiamenti di matricola motore da parte delle case automobilistiche, abbiamo sentito la necessità di offrire un prodotto che non

fosse ancora presente sul mercato. Da questa esigenza e dopo un'attenta ricerca **sono nati i nostri Kit unificati firmati Kortig.**

La nostra voglia di offrire prodotti di qualità per tutti i comparti automotive ci ha spinto a cercare nuove soluzioni migliorative ed efficienti sia per il settore delle **auto d'epoca**, fin dall'inizio nostra prima passione, che per il **ramo agricolo** da sempre fulcro del marchio tedesco.

ASIATICHE

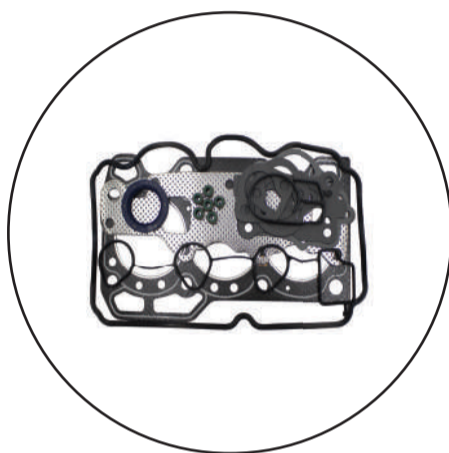

KIT 26.MATIZ
Serie smeriglio con guarnizione testa
Matiz 800cc 3 Cilindri

05.MATIZ



05.KALOS



KIT 26.KALOS
Serie smeriglio con guarnizione testa
Kalos 1200cc 4 Cilindri

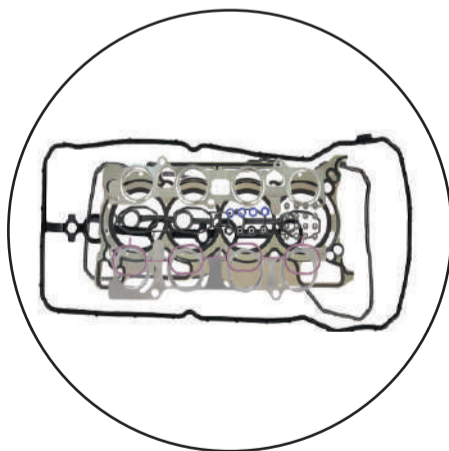
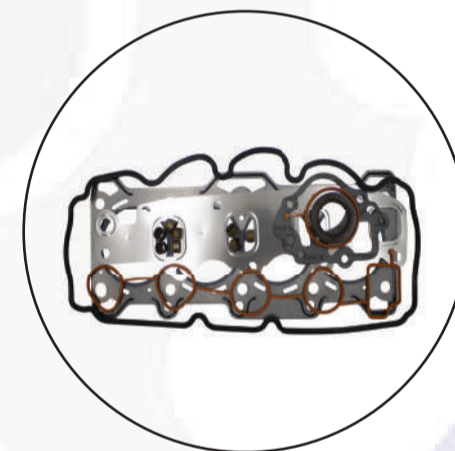

KIT 26.QASHQAI UNIFICATO
Serie smeriglio con guarnizione testa
Qashqai 1.6 16 valvole
HR16DE

FIAT



KIT 26.9499/2 UNIFICATO
Serie motore senza guarnizione testa
Multijet 1300 75 - 90 - 95 cv

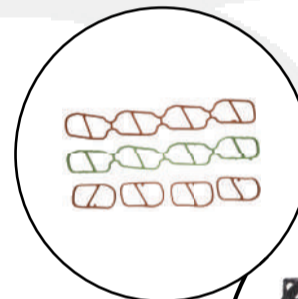

KIT 26.9499/1 UNIFICATO
Serie smeriglio senza guarnizione testa
Multijet 1300 75 - 90 - 95 cv

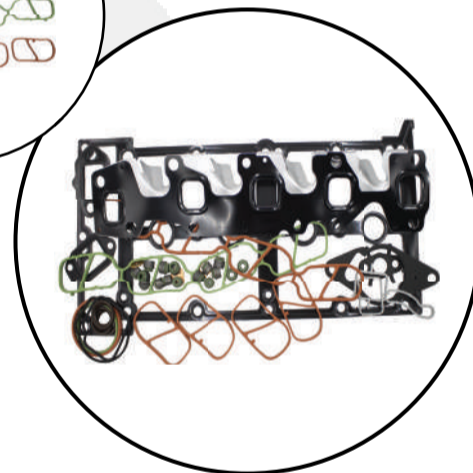

HBS353



AD5810 1 foro
AD5820 2 fori
AD5830 3 fori



FIAT

FIAT

Spessore
guarnizione testa
1,60 mm

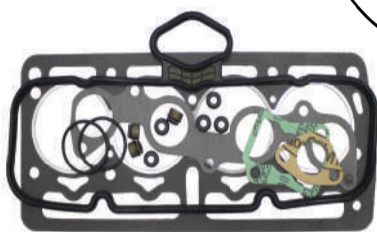

KIT 26.2409
Serie smeriglio con guarnizione testa
Cinquecento, Panda, Seicento 900cc.

HBS297



Ø 80,50 mm

HBS131



KIT CD5970
Serie smeriglio con guarnizione testa **in ferro**
Multipla, Doblò bipower 1.6 16 valvole

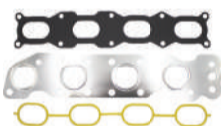

KIT 26.FIAT16 UNIFICATO
Serie smeriglio con guarnizione testa
Fiat - Suzuki 1300 cc 16 valvole

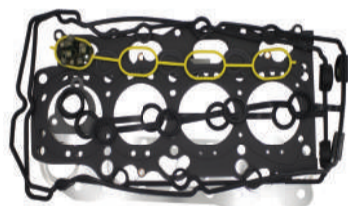

KIT CA5560/61 UNIFICATO
Serie smeriglio senza guarnizione testa
Multijet 1900 cc 16 valvole



FIAT

FIAT

VERSIONE GUARNIZIONE TESTA IN GLINGERITE

KIT 26.9160 UNIFICATO

Serie smeriglio con guarnizione testa **in glingerite**

Fire 1200 - 1400 cc **16 valvole**

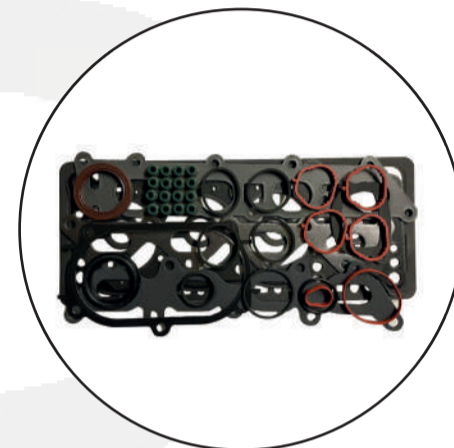

VERSIONE GUARNIZIONE TESTA IN FERRO

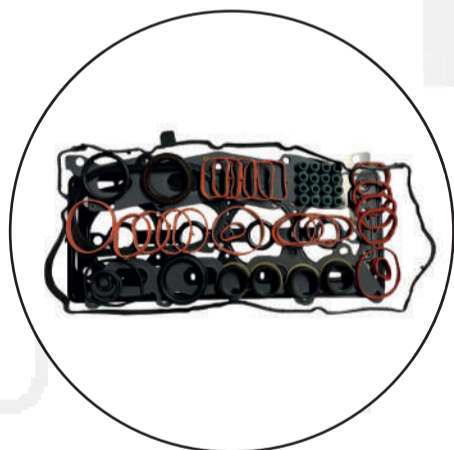

KIT 26.9160/1 UNIFICATO

Serie smeriglio con guarnizione testa **in ferro**

Fire 1200 - 1400 cc **16 valvole**

HBS247



FIAT

FIAT

VERSIONE GUARNIZIONE TESTA IN FERRO

KIT 26.1374 UNIFICATO

Serie smeriglio con guarnizione testa **in ferro**
Contiene boccole centraggio testa

Fire 1200 - 1400 cc **8 valvole**

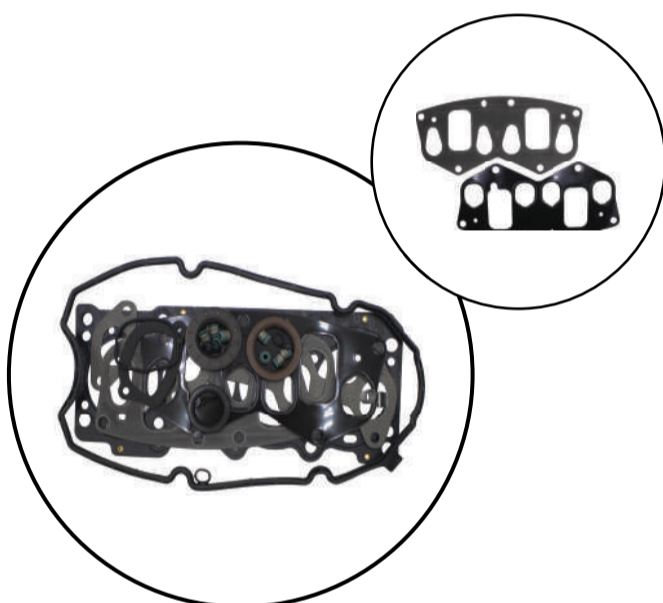
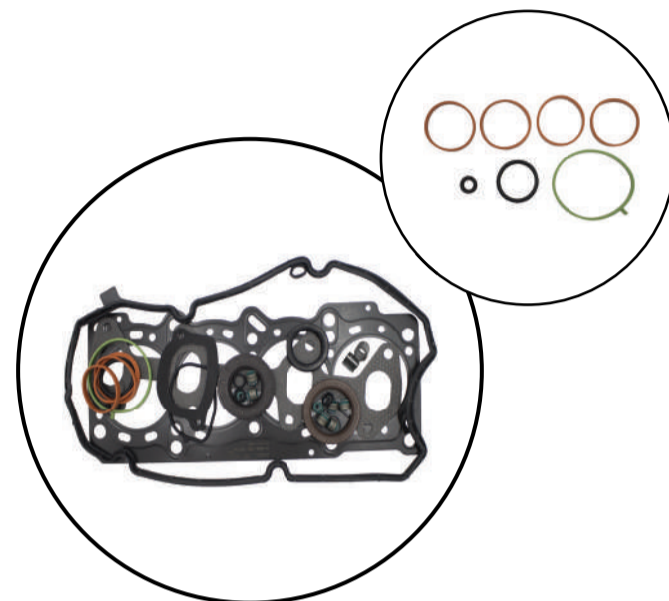

KIT 26.5118 UNIFICATO

Serie smeriglio con guarnizione testa **in ferro**
Contiene boccole centraggio testa

Fire 1200 - 1400 cc **8 valvole**

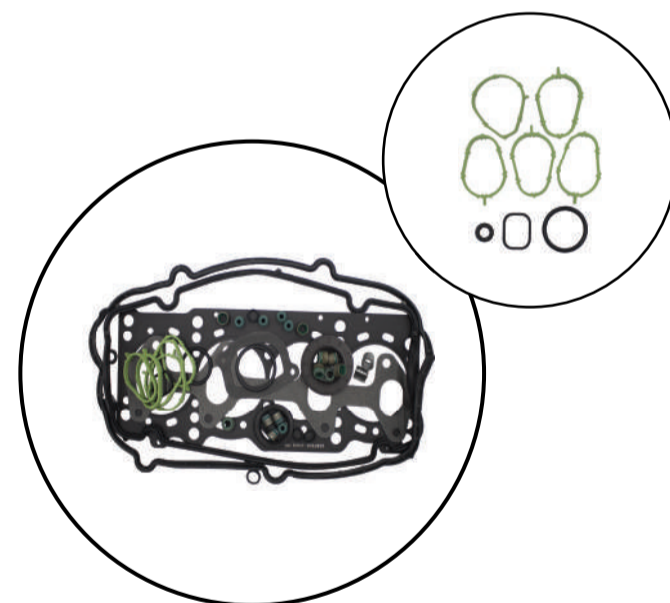

KIT 26.6244 UNIFICATO

Serie smeriglio con guarnizione testa **in ferro**
Contiene boccole centraggio testa

Fire 1200 - 1400 cc **8 valvole**

A.7696197



individuato il tipo di collettore di aspirazione si identifica la serie smeriglio idonea

FIAT

VERSIONE GUARNIZIONE TESTA IN GLINGERITE

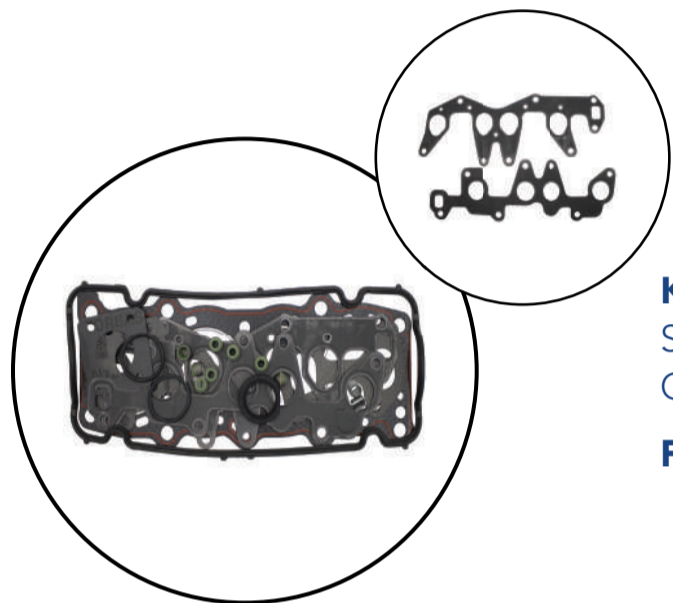

KIT 26.3661/1E UNIFICATO

Serie smeriglio con guarnizione testa **in glingerite**
Contiene boccole centraggio testa

Fire 1200 - 1400 cc **8 valvole Spi - Mpi**

KIT 26.6868/1E UNIFICATO

Serie smeriglio con guarnizione testa **in glingerite**
Contiene boccole centraggio testa

Fire 1200 - 1400 cc **8 valvole**

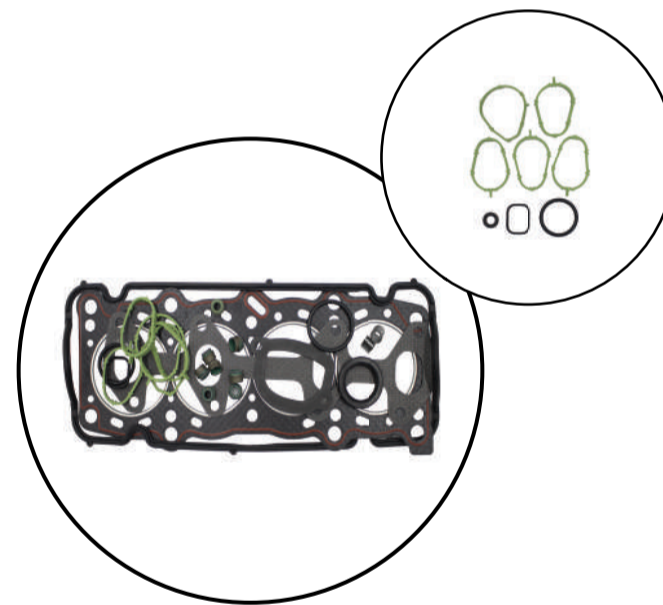

A.7696197



FIAT

OPEL

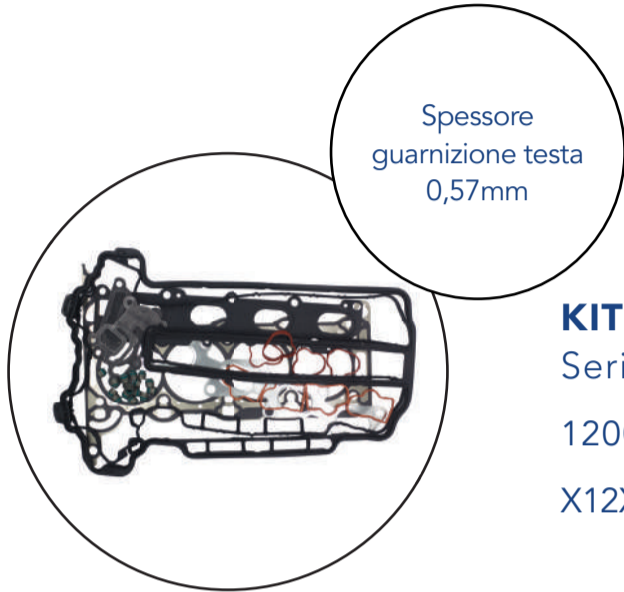

KIT 26.1606247 UNIFICATO
Serie smeriglio con testa
1200 - 1400 cc **4 cilindri 16 valvole**
X12XE, Z12XEP, Z14XEP, Z14XEL

HBS252

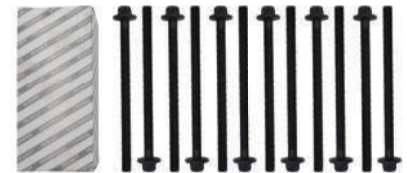

14-32331-01

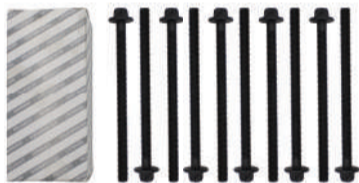

KIT 26.2606247 UNIFICATO

1400 cc **4 cilindri 16 valvole**
A12XEL, A12XER, A14XE, A14XER, A14NEL, A14NET,
B12XEL, B12XER, B14XEL, B14XEJ, B14XER, B14NEL,
B14NET, B14NEH, B14NEJ, B14NEL, B14NE

Spessore testa
0,77mm
Contiene salva testa
spessore 0,25 mm

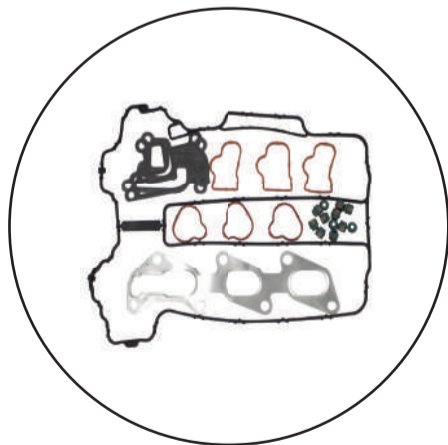
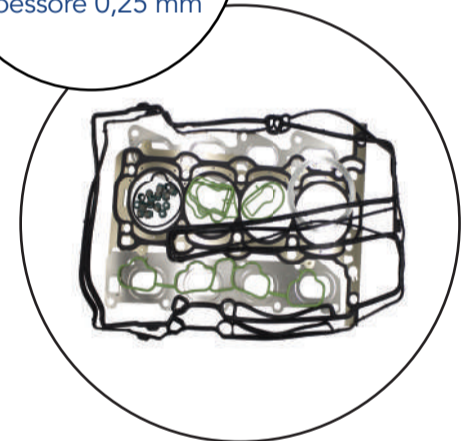

KIT 26.Z10XEP UNIFICATO

Serie smeriglio senza guarnizione testa
1000 cc **3 cilindri 12 valvole**
X10XE, Z10XE, Z10XEP

HBS253

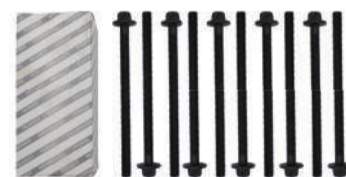

PEUGEOT



KIT 26.KFW UNIFICATO

Serie smeriglio con guarnizione testa
Contiene gommini iniettori

1400 cc **8 valvole**

TU3, TU3A, TU3CP, TU3M
K1D, KFV, KFW, KFX



HBS039

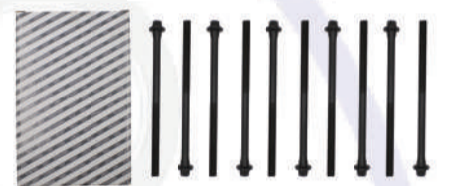

HBS039

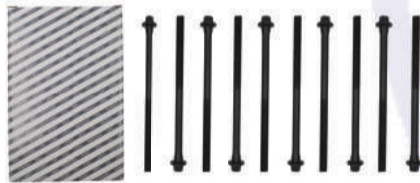

KIT 26.26100U UNIFICATO

Serie smeriglio con guarnizione testa
Contiene gommini iniettori

950 - 1000 - 1100 cc **8 valvole**

HFX, HFZ, TU1M, HDYORK, HDZ



KIT 26.KFU

Serie smeriglio con guarnizione testa

1400 cc **16 valvole**

KFU

05.KFU

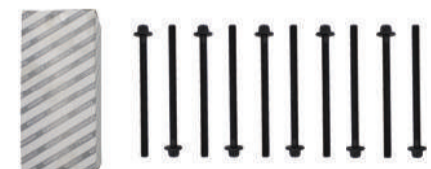

PEUGEOT

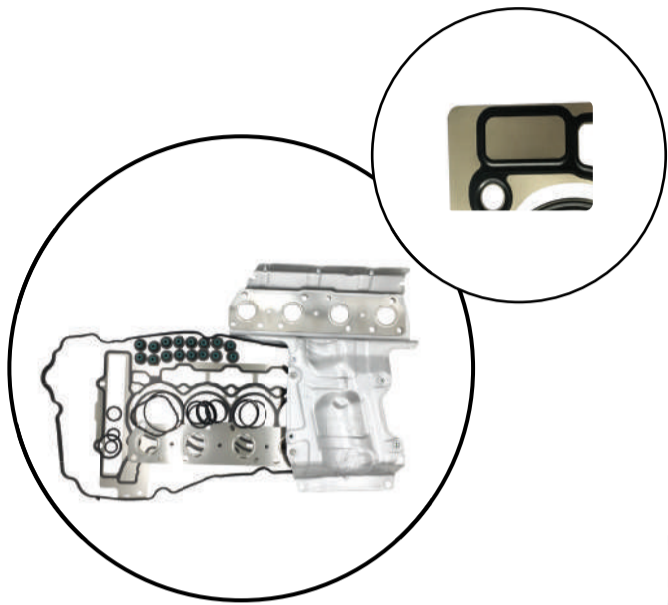

KIT 26.SSN12B14-16A

Serie smeriglio con guarnizione testa

1200 cc **16 valvole**

Citroen - Peugeot: 5FD, 5FS, 5FH, EP6D, 8FS, 8FN, 8FR, 8F02, 5FW, 5FK, 5FP, EP3
Mini: N12B16A , N14B16A, N14B16C

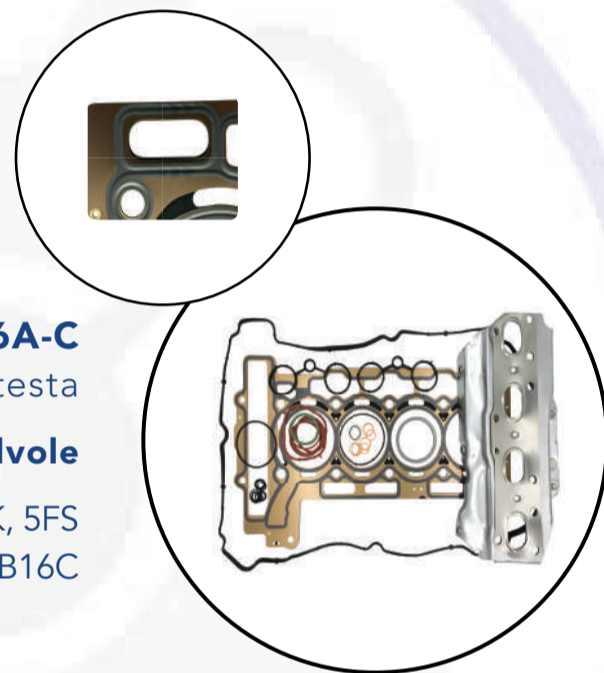

KIT 26.SSN14B16A-C

Serie smeriglio con guarnizione testa

1400 cc **16 valvole**

Citroen - Peugeot: N5F5, 5FK, 5FS
Mini: N14B16C



KIT 26.N18B16A

Serie smeriglio con guarnizione testa

1400 cc **16 valvole**

Mini: N13B16A, N18B16A



KIT 26.CN12B16A

Serie complementare

05.N14B16A



RENAULT

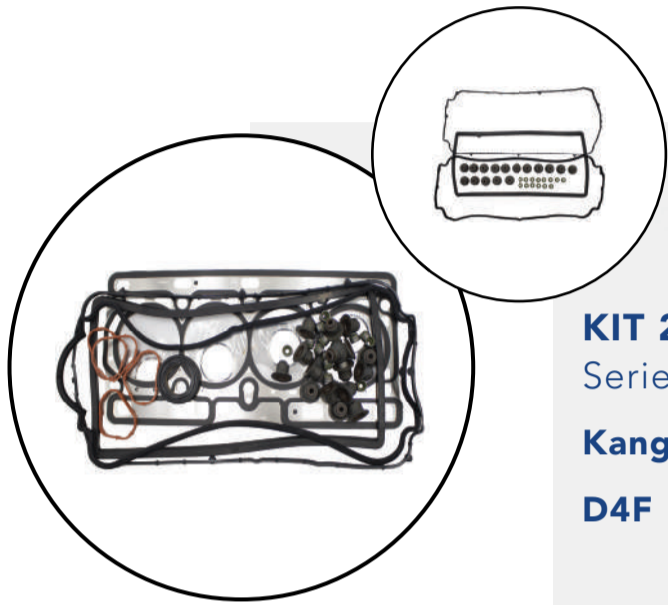

KIT 26.CD5980/81 UNIFICATO

Serie smeriglio con guarnizione testa

Kangoo 1200 cc **16 valvole**

D4F

HBS241



KIT 26.28934/4 UNIFICATO

Serie smeriglio con guarnizione testa

Kangoo 1100 cc **8 valvole**

D7F

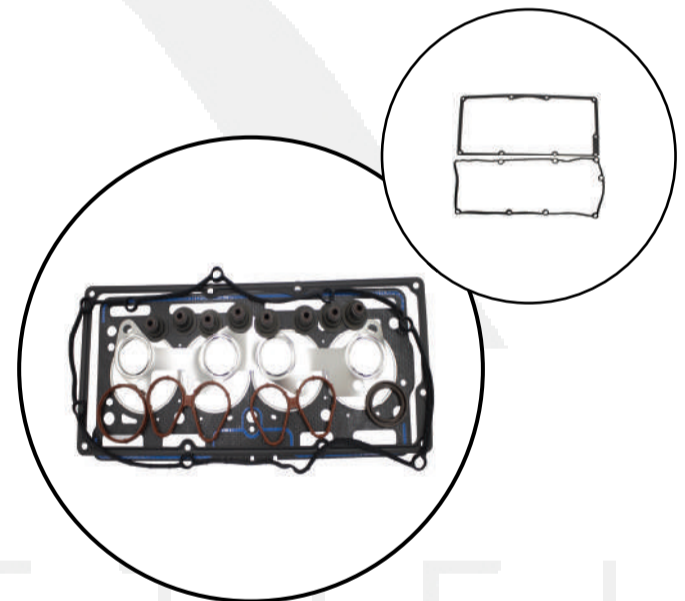

Scopri la gamma agricola

- Acme
- Aifo
- Carraro
- Cotiemme
- Deutz
- Fiat trattori - Fiat allis
- Om
- Lamborghini



- Lombardini
- Perkins
- Rugggerini
- Same
- Steyr
- Slanzi
- Vm

*Sul nostro catalogo **on-line parti motore***



AUTO D'ÉPOCA



KÖRTIG

Speciale



ALFA ROMEO

Modello	Cilindrata	Alesaggio	Anno	N° Cilindri	S. Motore S/TC	Testa cil.	Mat.
1750 - 1750 GT Sport	1779 cc	Ø 80	1968/72	4L	VSM/005	VTC/005	AF
1900 - 1900 Ti (Standard)	1975 cc	Ø 82,55	1950/53	4L	VSM/289	VTC/169	AF
1900 SUPER SPRINT	1975 cc	Ø 84,5	1955/58	4L	VSM/289	VTC/170	AF
1900 "LA MATTA"	1975 cc	Ø 82,55	1955/58	4L	VSM/290	VTC/169	AF
2000 GT - VELOCE	1975 cc	Ø 84,5	1957/62	4L	VSM/291	VTC/170	AF
2000 SPYDER GT	1962 cc	Ø 84	1971	4L	VSM/005	VTC/006	AF
2600 SPRINT SPYDER S e V	2548 cc	Ø 83	1962/66	6L	VSM/292	VTC/171	AF
GIULIA 1300 UNIFICATA	1290 cc	Ø 74	1964/68	4L	FF24RU	VTC/002	AF
GIULIA 1600 UNIFICATA	1570 cc	Ø 78	1965/72	4L	FF24RU	VTC/003	AF
GIULIETTA I/S	1290 cc	Ø 74	1955/58	4L	VSM/293	VTC/172	AF
GIULIETTA II/S - SPRINT	1290 cc	Ø 74	1959/62	4L	VSM/308	VTC/361	AF
MONTREAL 2600	2593 cc	Ø 80	1970/77	V8	VSM/433 - (con 2 TC)	VTC/481 - VTC/482 -	AF

N.B. - Le serie motore sono disponibili (su richiesta) complete di paraoli

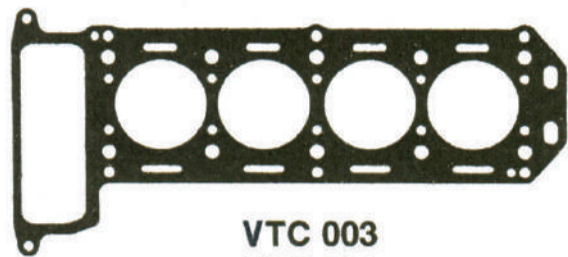

VTC 003
VTC 002

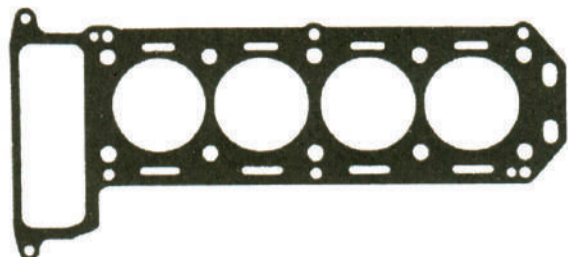

VTC 005

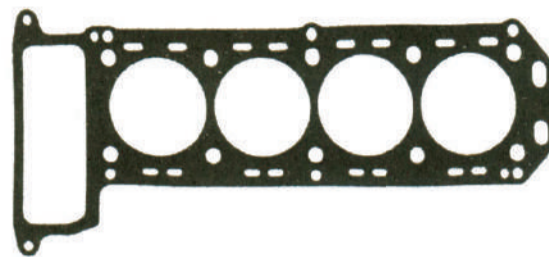

VTC 006

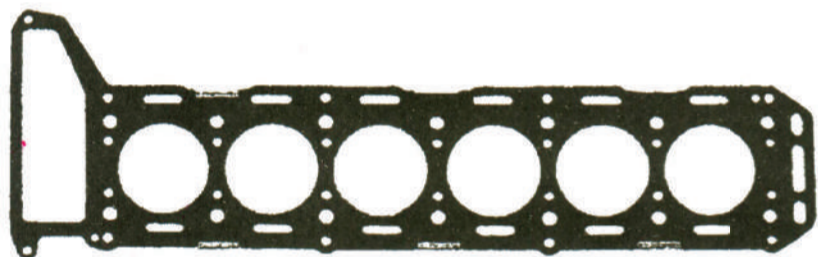

VTC 171

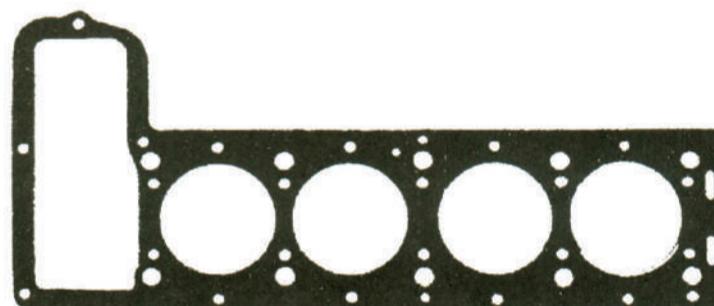

VTC 169
VTC 170

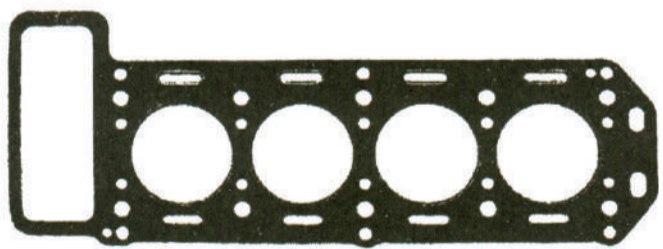

VTC 172

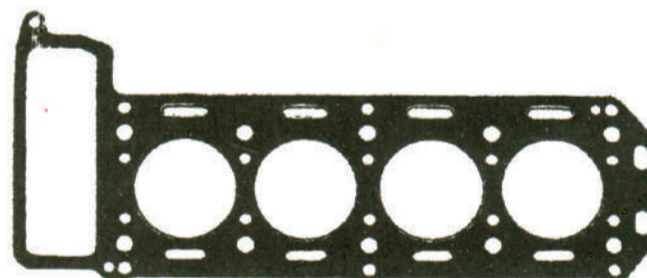

VTC 361

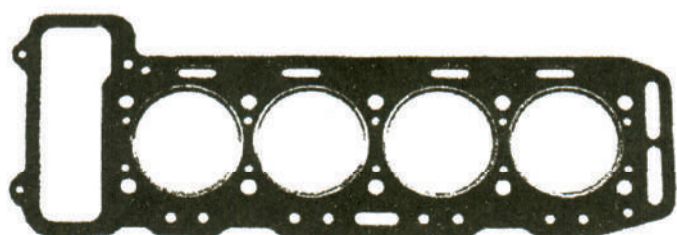

VTC 481

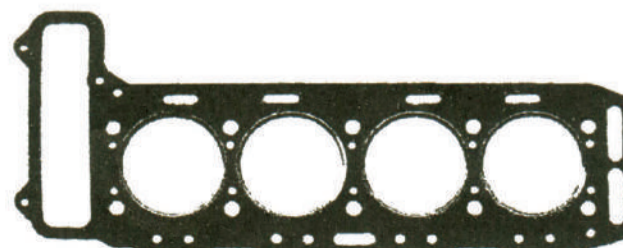

VTC 482

Modello	Cilindrata	Alesaggio	Anno	N° Cilindri	S. Motore S/TC	Testa cil.	Mat.
500 A	570 cc	Ø 52	1936/48	4L	26.500A	VTC/016	RAF
500 B-C Berlina/Belvedere	570 cc	Ø 52	1949/55	4L	26.500C	VTC/017	AF
500 ND - Berlina	499,5 cc	Ø 67,4	1957/65	2L	26.04201	VTC/022	AF
500 D Giardiniera	499,5 cc	Ø 67,4	1960/65	2L	26.500GIAR	VTC/022	AF
508 Balilla 3/4 Marce	995 cc	Ø 65	1932/34	4L	26.BALILLA	VTC/179	RAF
508 "Coppa oro"	995 cc	Ø 65	1932/34	4L	VSM/299	VTC/180	RAF
508/C	1089 cc	Ø 68	1937/52	4L	VSM/297	VTC/173	AF
600 I^a/S-Multipla	633 cc	Ø 60	1955/60	4L	26.600ISR	VTC/020/1	AF
600 D-E-Multipla	767 cc	Ø 62	1960/68	4L	26.600D	VTC/020	AF
126	600 cc	Ø 73,5		2L	26.126600		AF
126	650 cc	Ø 77		2L	26.09571		AF
126 Bis		Ø 80		2L	5891798		AF
127 Uno 45	903 cc	Ø 65		4L	26.04161		AF
Panda 30	650 cc	Ø 77		2L	5892398		AF

N.B. - Le serie motore sono disponibili (su richiesta) complete di paraoli

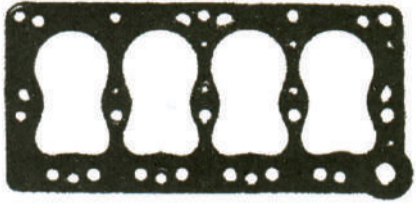

VTC 016

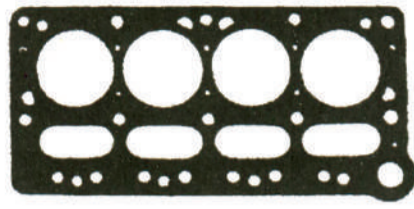

VTC 016/A

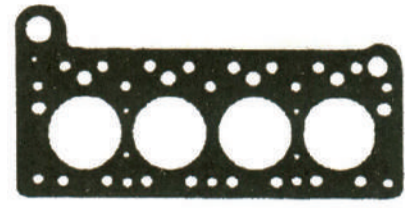

VTC 017

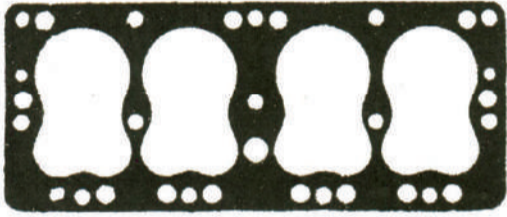

VTC79

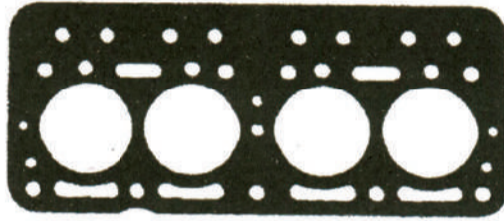

VTC80

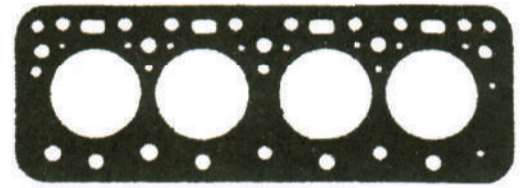

VTC73



VTC 022

Modello	Cilindrata	Alesaggio	Anno	N° Cilindri	S. Motore S/TC	Testa cil.	Mat.
850 Berlina-Special-Coupé	843 cc	Ø 65	1965/71	4L	26.850	V TC/029s	AF
1100 ABE	1089 cc	Ø 68	1939/50	4L	26.1100E	V TC/173	AF
1100/103 Iª Serie	1089 cc	Ø 68	1953/57	4L	V SM/294	V TC/173	AF
1100/103 IIª/s-103/58	1089 cc	Ø 72	1953/58	4L	V SM/295	V TC/174	AF
1100/103 H	1089 cc	Ø 68	1959/60	4L	26.1100D	V TC/175	AF
1100/D-1200	1221 cc	Ø 72	1957/60	4L	26.1100D	V TC/176	AF
1100/R	1089 cc	Ø 68	1966/69	4L	26.1100A	V TC/032	AF
1300	1295 cc	Ø 72	1961/64	4L	V SM/034	V TC/033	AF
1400 AB-1400 Iª e IIª/S	1395 cc	Ø 82	1950/54	4L	V SM/041	V TC/057	RAF
1500-1500 C-L (Mot. 115c)	1481 cc	Ø 77	1961/64	4L	V SM/034	V TC/034	AF
1500-1500 E "Musone"	1493 cc	Ø 65	1935/50	6L	V SM/424	V TC/253	AF
1500 S-Osca (Mot. 118)	1491 cc	Ø 78	1960/62	4L	V SM/038	V TC/058	AF
1600 S-Cabriolet	1568 cc	Ø 80	1962/66	4L	V SM/038	V TC/059	AF
1800 Berlina	1795 cc	Ø 72	1958/61	6L	V SM/300	V TC/184	AF
1800 B-2100-2300	2279 cc	Ø 78	1962/68	6L	V SM/300	V TC/185	AF
1900-Campagn. AR/51	1901 cc	Ø 82	1952/54	4L	26.SMCAMPAGNOLA	TC/057	RAF

N.B. - Le serie motore sono disponibili (su richiesta) complete di paraoli

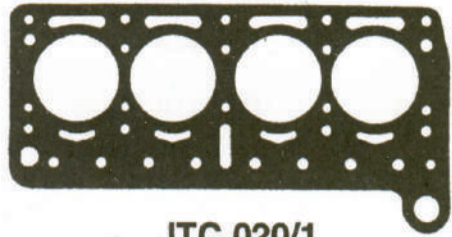

ITC 020/1

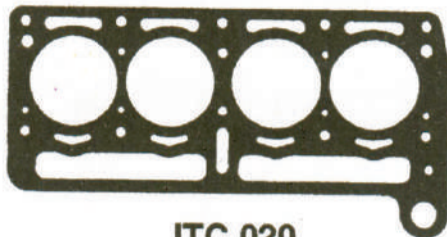

ITC 020

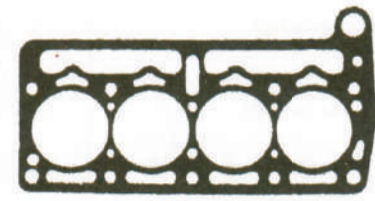

ITC 029s

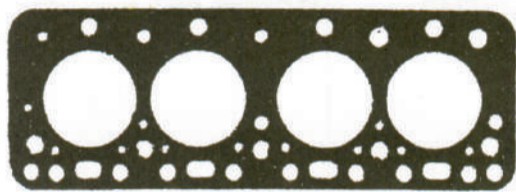

ITC 173
ITC 174

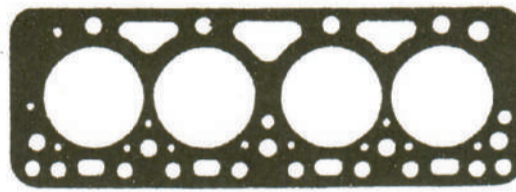

ITC 175

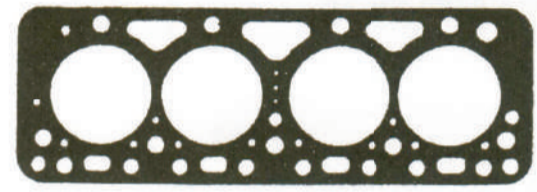

ITC 176

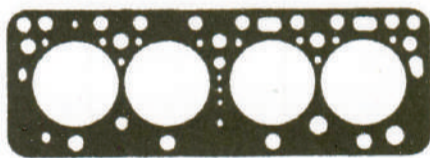

ITC 032

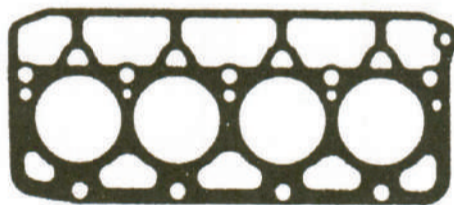

ITC 033

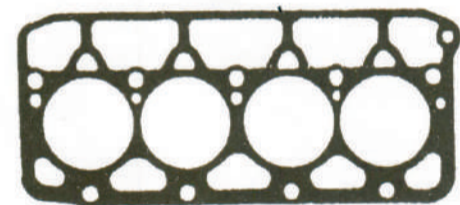

ITC 034

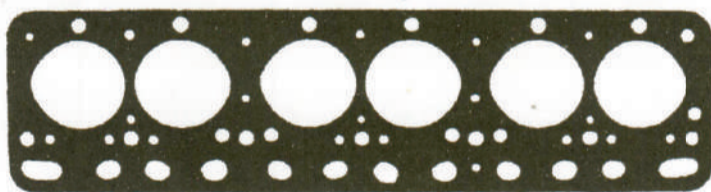

ITC 253

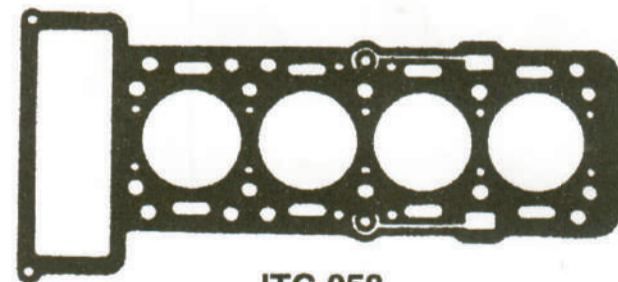

ITC 058
ITC 059

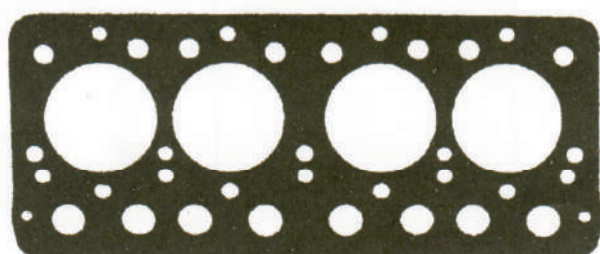

ITC 057
ITC 057/A

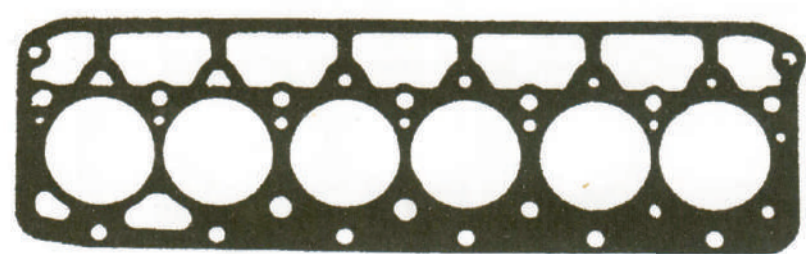

ITC 184
ITC 185

Modello	Cilindrata	Alesaggio	Anno	N° Cilindri	S. Motore S/TC	Testa cil.	Mat.
125-125 Special	1608 cc	Ø 80	1965/71	4L	VSM/033	VTC/040	AF
130 Berlina 2800	2866 cc	Ø 96	1969/71	V6	VSM/049	VTC/010	AF
130 Berlina/Coupé 3200	3235 cc	Ø 102	dal 1971	V6	VSM/052	VTC/013	AF
X 1/9-1300 Spyder	1290 cc	Ø 86	1972/78	4L	VSM/426	VTC/037	AF
X 1/9-1500 Speed	1498 cc	Ø 86,4	1972/78	4L	VSM/427	VTC/110	AF
Dino 2000 Coupé	1987 cc	Ø 86	1967/69	6V	VSM/039	TC/060-061	AF
Dino 2400 Coupé	2418 cc	Ø 92,5	1969	6V	VSM/040	TC/066-067	AF

N.B. - Le serie motore sono disponibili (su richiesta) complete di paraoli

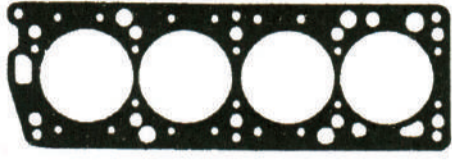

VTC 040

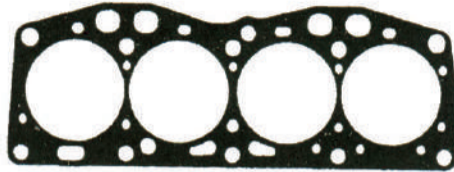

VTC 037

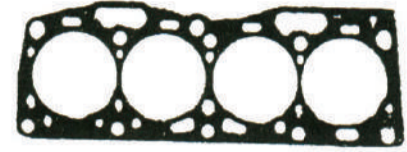

VTC 110

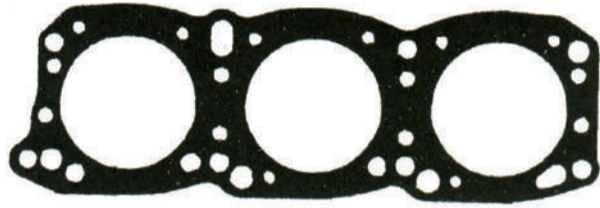

VTC 010

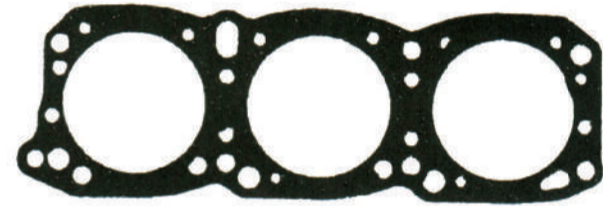

VTC 013

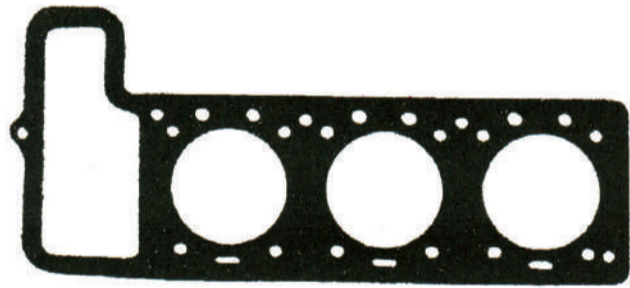

VTC 060

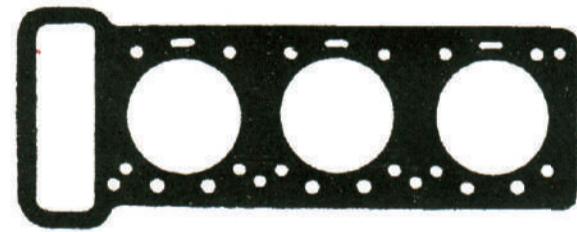

VTC 061

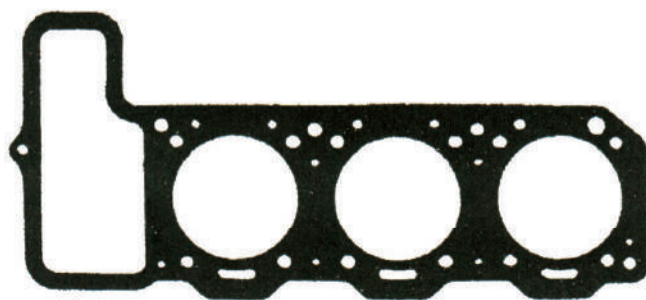

VTC 066

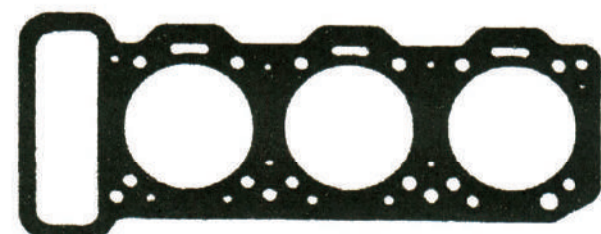

VTC 067

LANCIA

Modello	Cilindrata	Alesaggio	Anno	N° Cilindri	S. Motore S/TC	Testa cil.	Mat.
APPIA I^a/Serie	1089 cc	Ø 68	1953/56	4	SM/301	VTC/186	RAF
APPIA II^a-III^a Serie	1090 cc	Ø 68	1956/63	4	SM/302	VTC/187	RAF
APRILIA 1350-1500	1351-1486cc	Ø 75	1937/48	4	SM/425	VTC/188	RAF
ARDEA 6V	903 cc	Ø 65	1939/48	4	SM/303	VTC/189	RAF
ARDEA 12V	903 cc	Ø 65	1948/53	4	SM/303	VTC/190	RAF
AURELIA B 10	1754 cc	Ø 70	1950/54	V6	SM/304	VTC/193	AF
AURELIA B 20 I^a/II^a S	1991 cc	Ø 72	1951/53	V6	SM/304	VTC/193 A	AF
AURELIA B 15-22	1991 cc	Ø 72	1952/57	V6	SM/304	VTC/194	AF
AURELIA B 12	2286 cc	Ø 75	1954/59	V6	SM/304	VTC/194 A	AF
AURELIA B 20-2500 GT	2451 cc	Ø 78	1953/59	V6	SM/304	VTC/195	AF
FLAMINIA 2500	2458 cc	Ø 80	1957/61	V6	SM/305	VTC/196	RAF
FLAMINIA 2800	2775 cc	Ø 85	1963/69	V6	SM/305	VTC/197	AF
FLAVIA 1500	1490 cc	Ø 80	1960/70	4V	SM/306	VTC/198	AF
FLAVIA 1800	1815 cc	Ø 88	1962/70	4V	SM/306	VTC/199	AF
FLAVIA 2000	1991 cc	Ø 89	1969/71	4V	SM/307	VTC/095	AF

N.B. - Le serie motore sono disponibili (su richiesta) complete di paraoli

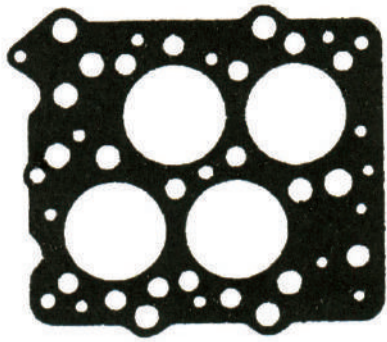

VTC 186

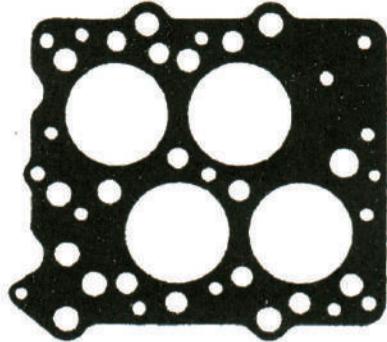

VTC 187

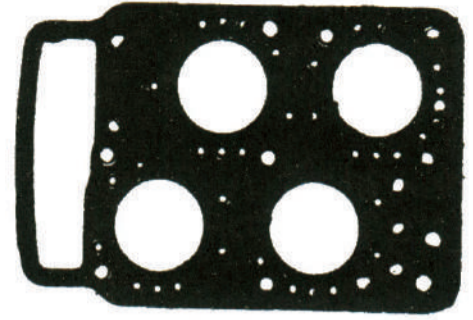

VTC 188

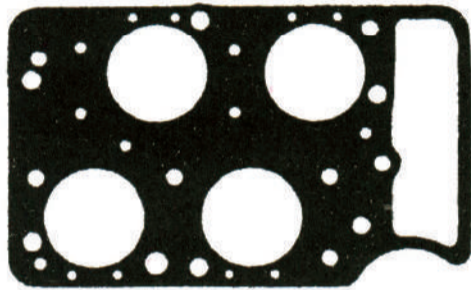

VTC 189

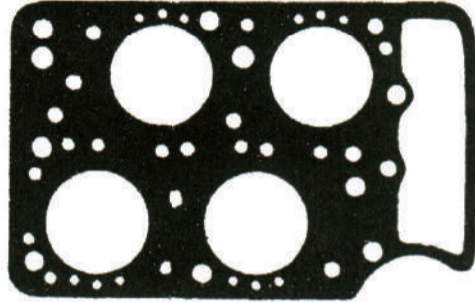

VTC 190

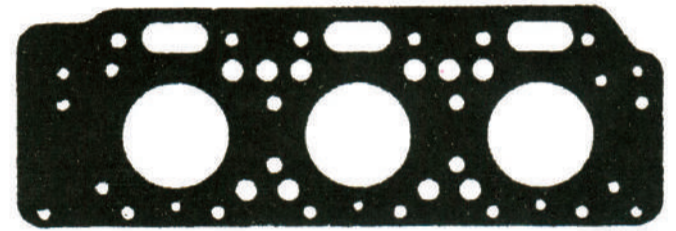

ITC 193

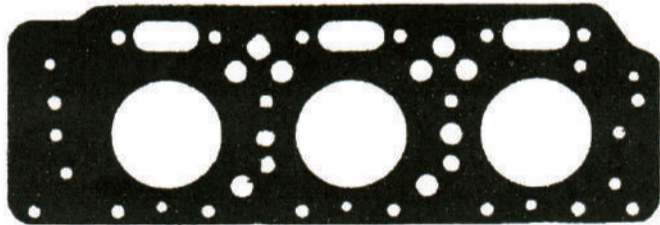

ITC 194

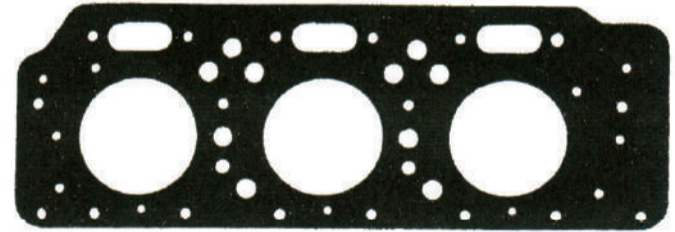

ITC 195

LANCIA

Modello	Cilindrata	Alesaggio	Anno	N° Cilindri	S. Motore S/TC	Testa cil.	Mat.
FULVIA 1100 I°/S (Mot.818000)	1091 cc	Ø 72	1963/64	4	VSM/053	VTC/053	AF
FULVIA 2/C 1100 (Mot.818000)	1091 cc	Ø 72	1964/67	4	VSM/054	VTC/054	AF
FULVIA GT-Coupé-1300	1298 cc	Ø 77	dal 1964	4	26.FULVIA13	VTC/055	AF
FULVIA HF 1600-Coupé	1584 cc	Ø 81	dal 1970	4	VSM/056	VTC/056	AF
GAMMA 2000	1999 cc	Ø 91,5	dal 1976	4V	VSM/346 C/2TC	VTC/403	AF
GAMMA 2500	2484 cc	Ø 102	dal 1980	4V	VSM/347 C/2TC	VTC/404	AF

N.B. - Le serie motore sono disponibili (su richiesta) complete di paraoli

MASERATI

Modello	Cilindrata	Alesaggio	Anno	N° Cilindri	S. Motore S/TC	Testa cil.	Mat.
BITURBO 2000	2000 cc	Ø 84	-	V6	SMERIGLIO*	ITC/479	AF
BITURBO 2500	2500 cc	Ø 95	-	V6	SMERIGLIO*	ITC/480	AF

*** - Disponibile solo la serie Smeriglio S/TC e S./Paraoli**

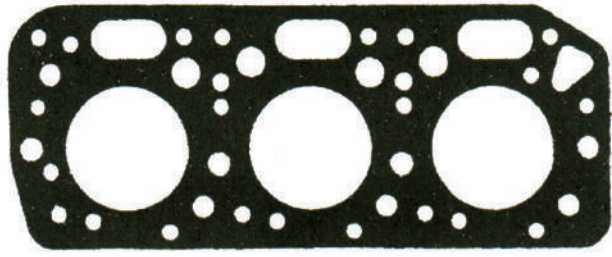

VTC 196

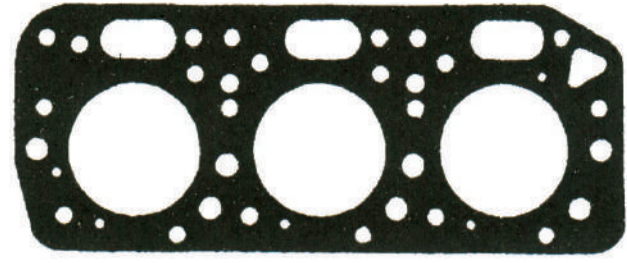

VTC 197

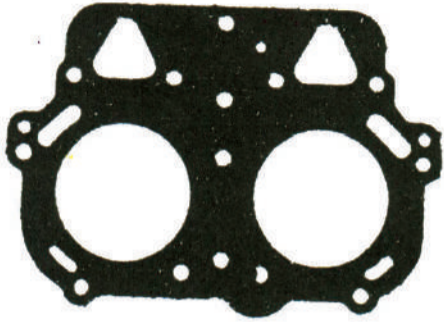

VTC 198
VTC 199
VTC 095

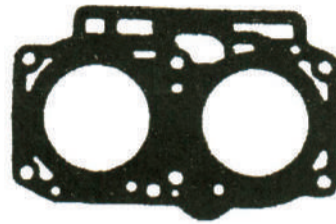

VTC 403
VTC 404



VTC 053

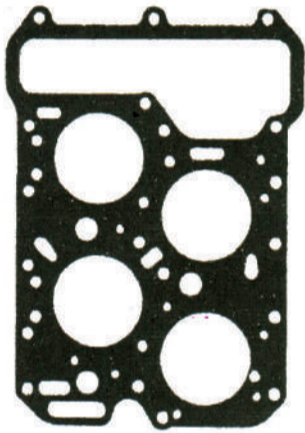

VTC 054

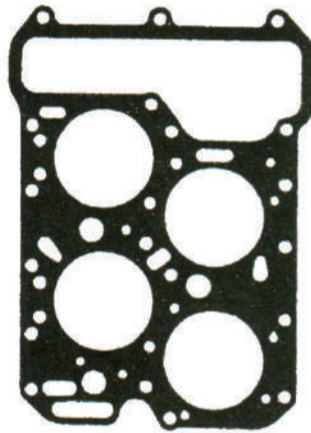

VTC 055

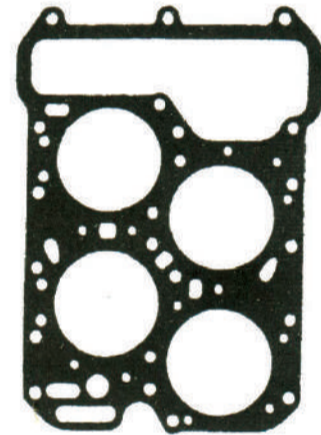

VTC 056

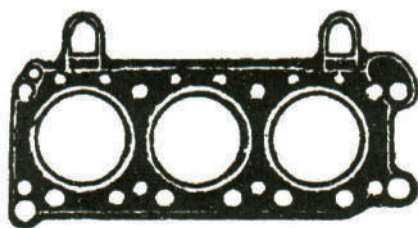

VTC 479

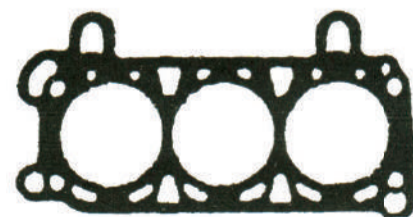

VTC 480

FORD

Modello	Cilindrata	Alesaggio	Anno	N° Cilindri	S. Motore S/TC	Testa cil.	Mat.
CAPRI 1300 (Motore a V)	1305 cc	Ø 84	dal 1964	4V	VSM/428 C/2TC	TC/469-470	AF
CAPRI 1500-1700 (Motore a V)	1305 cc	Ø 84	dal 1969	4V	VSM/429 C/2TC	TC/471-472	AF
CAPRI 2300 (Motore a V)	2293 cc	Ø 90	dal 1969	6V	VSM/430 C/2TC	TC/473-474	AF
TAUNUS 12 M (Motore a V)	1183 cc	Ø 80	dal 1962	4V	VSM/431 C/2TC	TC/475-476	AF
TAUNUS 20 M (Motore a V)	1998 cc	Ø 84	dal 1964	6V	VSM/432 C/2TC	TC/477-478	AF

N.B. - Le serie motore sono disponibili (su richiesta) complete di paraoli



VTC 469



VTC 470



VTC 471



VTC 472



VTC 473



VTC 474



VTC 475



VTC 476



VTC 477

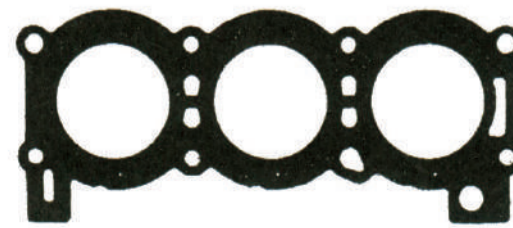

VTC 478

NSU

Modello	Cilindrata	Alesaggio	Anno	N° Cilindri	S. Motore S/TC	Testa cil.	Mat.
PRINZ 4L	598 cc	Ø 76	1957	4L	SM/071 C/TC	VTC/071	AF
PRINZ 1000-110	996 cc	Ø 69	1964	4L	SM/072 C/TC	VTC/072	AF

N.B. - Le serie motore sono disponibili (su richiesta) complete di paraoli



VTC 071



VTC 072

VOLKSWAGEN

Modello	Cilindrata	Alesaggio	Anno	N° Cilindri	S. Motore S/TC	Testa cil.	Mat.
MAGGIOLINO 1200/1300	1192-1285 cc	Ø 77	1954/65	4	26.MAGGIOLINO		
MAGGIOLONE 1500/1600 UNIFICATA	1493-1584cc	Ø 83	1954/65	4	26.MAGGIOLINO		

N.B. - Le serie motore sono disponibili (su richiesta) complete di paraoli

SEI INTERESSATO AI NOSTRI SERVIZI?

DOVE CI TROVI

**Via Lombardia, 6
25033 Cologne
Brescia
Italia**

**CONTATTI:
TELEFONO
+39 030 7050590 - 030 7050622**

**AMMINISTRAZIONE
(INT. 1) alessandra.viola@tuttorettifiche.it**

**COMMERCIALE ITALIA
(INT. 3) antonio.viola@tuttorettifiche.it
(INT. 2) lorenzo.viola@tuttorettifiche.it**

**COMMERCIALE ESTERO
(INT. 3) antonio.viola@tuttorettifiche.it**

**MAGAZZINO
(INT. 4) info@tuttorettifiche.it**

**INFORMAZIONI
info@tuttorettifiche.it**

**WHATSAPP
+39 371 5839178**



TR

TUTTORETTIFICHE®